



ETO SERIES

Hi-Rel 4,200W AC/DC POWER SUPPLY



FEATURES

- 4,200 W Output Power
- 205~305 VAC Input
- Over Voltage Protection
- Over Current Protection
- Conformal Coating (optional)
- HI-Reliability, SEMI F-47 Compliant
- OPTIONS: Factory Configurable voltage 9~55 VDC, Multiple Isolated Outputs (up to 3)
- Conducted Emission and Reinforcement in observance with MIL STD 461 (Conducted Emissions for 100~264 VAC) and MIL STD 810G (Shock/Vibration) available



INPUT			
Voltage/Freq	V	AC 205-270 VAC (AC190~305) 50/60 Hz (47~63Hz) (If Operating at AC85~170, Derate to 60% Load)	
Current	A	30A MAX	
Power Factor	220V	0.95 typ; 0.985 @ Full Load	
Inrush Current	A	75 @ 277 VAC in (worst case)	
Leakage	mA	<2.8 mA ACIN 240V 50Hz, Io=100%,	

SINGLE OUTPUT MODELS

			ETO-24SX-25	ETO-28SX-25	ETO-48SX-25	ETO-55SX-25	ETO-110SX-25
OUTPUT	Nominal Voltage	VDC	24	28	48	55	110
	Current	A	150	150	87.5	76.4	38.2
	Efficiency typ	%	87	87	89	88	88
	@Full Load		89	89	90	89	89
	Line/Regulation	%	+/-1.5	+/-1.5	+/-1.5	+/-1.5	+/-1.5
	Ripple/Noise	%	+/- 1 max	+/- 1 max	+/- 1 max	+/- 1 max	+/- 1 max
	Temp Drift	%	<1%	<1%	<1%	<1%	<1%
	Rise Time	mS	600 max	600 max	600 max	600 max	600 max
	Hold up Time	mS	>22 typ [AC IN 110V, Io =100%]				
	OVP	VDC	27~32	35~39 VDC	55.2~60	63~66	115~120
	OCP		105% of of rated current, constant Current to hiccup, automatic recovery				
	Cooling		Forced Air				

1. Ripple and noise are measured using oscilloscope 20MHz bandwidth by a 10uF electrolytic capacitor and a 0.1uF ceramic capacitor in parallel at output connector.
2. Standards: Unit has been designed to meet the standards listed. It is the responsibility of the customer to test in their system. Conducted emissions using shielded 3 conductor cable (L,N,G) with unit mounted to chassis ground.
3. Contact factory for test conditions.
4. ETO-24 & 28 models must use busbars.



DUAL OUTPUT MODELS

For Dual Output Models, yy=rated secondary voltage output

MULTIPLE OUTPUT MODELS

MULTIPLE OUTPUT MODELS								
OUTPUT	V1	Voltage	VDC	12	24	28	48	55
		Current	A	45	44.4	43	45	45
	V2	Voltage	VDC	12	24	28	48	55
		Current	A	45	44.4	38.07	22.21	19.5
	V3	Voltage	VDC	12	24	28	48	55
		Current	A	45	44.4	38.07	22.21	19.5
	Efficiency typ		%	84	87	87	89	88
	@Full Load			85	89	89	90	89
	Line/Regulation		%	+/-1.5	+/-1.5	+/-1.5	+/-1.5	+/-1.5
	Ripple/Noise		%	+/- 1 max	+/- 1 max	+/- 1 max	+/- 1 max	+/- 1 max
	Temp Drift		%	<1%	<1%	<1%	<1%	<1%
	Rise Time		mS	600 max	600 max	600 max	600 max	600 max
Hold up Time		mS	>22 typ [AC IN 110V, I _o =100%]					
OVP		VDC	14~16 VDC	27~32	35~39 VDC	55.2~60	63~66	
OCP		105% of of rated current, constant Current to hiccup, automatic recovery						
Cooling		Forced Air						

*For triple output model model number is determined by the following scheme, ETN-V1_V2_V3_V3_X-25 where V1_, V2_, and V3_ designate the selected output voltage

Protection	Overvoltage	Shutdown and latch off; AC recycle to restart
	Overload/Over Current	Constant Current to Hiccup, Auto recovery
	Over Temperature	Output shutoff when internal temperature reaches 85~90°C, AC recycle once overtemperature condition has been removed
Isolation	Input-Output	AC 3,000V 1 minute current 20mA, DC 500V 50MΩ (At room temperature & Humidity)
	Input-Case	AC 2,000V 1 minute current 20mA, DC 500V 50MΩ (At room temperature & Humidity)
	Output-Case	AC 500V 1 minute current 100mA, DC 500V 50MΩ (At room temperature & Humidity)
Environment	Operating temp/ Humidity	-40~ +70°C Ambient 20 ~ 95% RH(Non condensing)
	Storage temp/ Humidity	-40 ~ +100°C, 20 ~ 98% RH(Non condensing)
	Vibration	10 ~ 55Hz at 1G, 3 minutes period, 30 minutes along X, Y and Z axis
	Impact	2G for 20ms once on each X, Y and Z axis
Safety	UL/CE	Meets UL62368-1, EN62368-1, Complies with IEC60601-1-2 4th
	EMC	Complies with IEC61000-3-2 (Class A and B) EN55032 class A MIL-STD-461F/G: CE102, RE102, RE103
Size	In/lbs	14x5x5 inches /15 lbs
MTBF	Hrs	>250,000 at 25°C Ambient



Options	Suffix	Description
Remote ON OFF	-R1	Open=On/ Short =Off
	-R2	Open=Off/ Short=On
Voltage Trim	-VT	+/- 20% output voltage trim via external potentiometer (available on 28V and +10/-20% for 48V models only)
Output Current Monitor	-IM	1.25V~3.25V = 0~100% Iout. +/-10%
Remote Sensing	-S	+S, -S on DB9 connector
Power Good	-PG	Output Power Monitor. Low= Good; High = Bad
Conformal Coat	-CC	Acrylic Coat on Internal Electronics
Buss Bar	-B	+/- Vout via buss bar contact, mandatory for 28V option
Conducted Emissions	-CE2	Modification to comply with MIL STD 461 CE 101, CE102 EMI Requirements
Vibration reinforcement	-8G	Modified to handle high vibration and shock environments, designed against MIL STD 810G

*-VT, -IM, -S, -PG options not available for 110V model and multiple output models

Control Options Via Female DB9 Style Connector

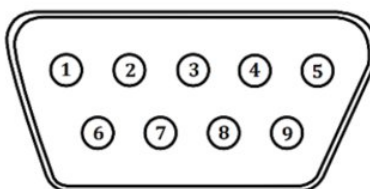

Pin #	Name	Function
1	+S	+Sense
2	RC1	Remote control; on/off
3	RAX	Remote Auxiliary control (for remote on/off)
4	PG	Power Good Signal, to be used with PGG
5	NC	No connection
6	-S	-Sense
7	RC2	Remote control; on/off
8	PGG	Power Good Ground, to be used with PG
9	Imon	Output current monitor, to be used with -S

PART NUMBER SELECTION

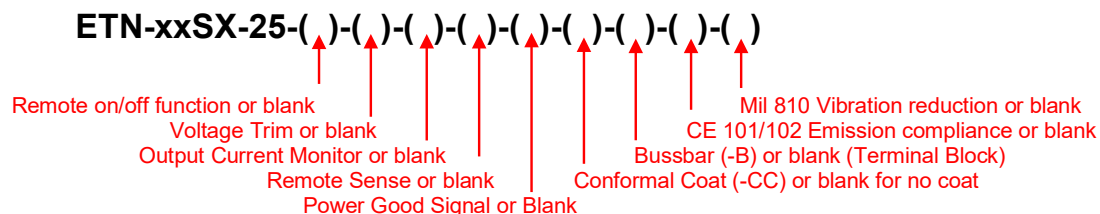



DERATING

Output Load vs Ambient Temperature

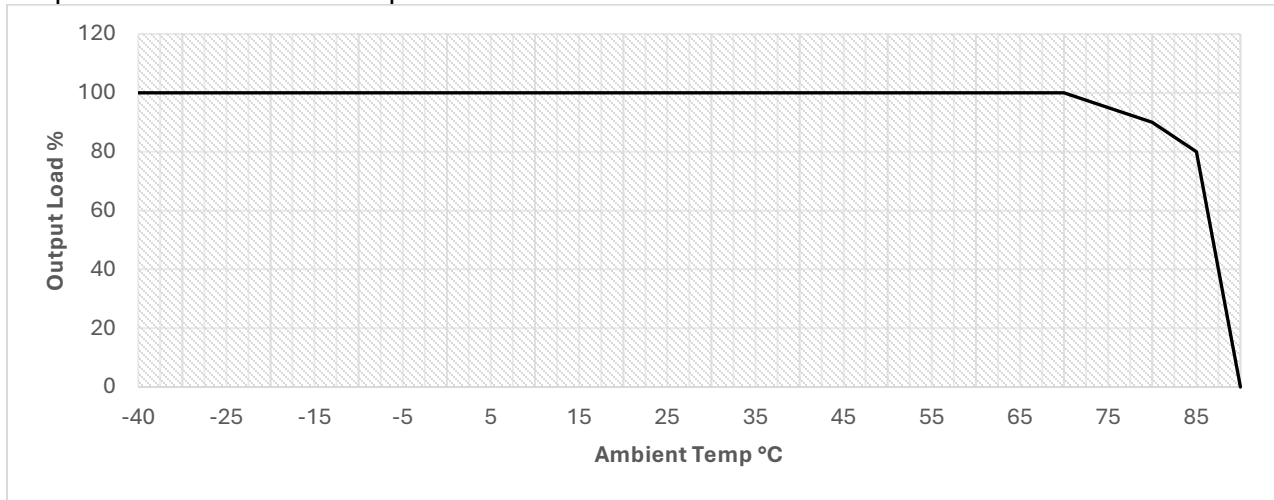



INTERFACE/CONNECTORS

ETO-24SX-25 / ETO-28SX-25 / ETO-48SX-25

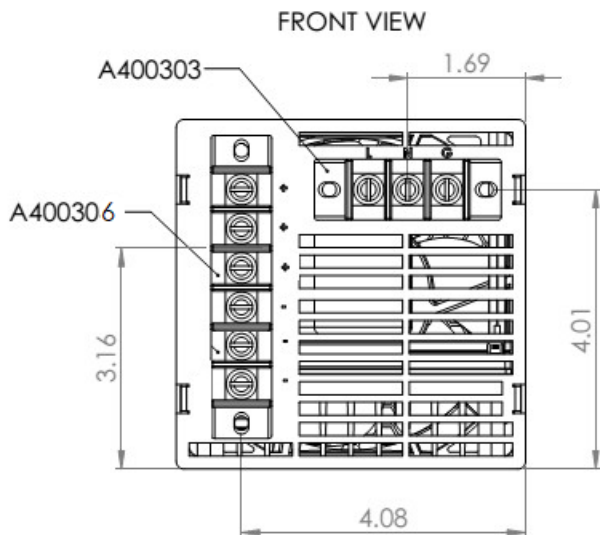

INPUT INTERFACE TERMINAL BUCHANAN A400303	
Designation	Function
L	Line
N	Neutral
G	Ground

OUTPUT INTERFACE TERMINAL BUCHANAN A400306 (Top to bottom)	
Designation	Function
+	+Vout
+	+Vout
+	+Vout
-	Vout Return
-	Vout Return
-	Vout Return

**For multiple output model, 1st and 2nd position for V1, 3rd & 4th position for V2, and 5th & 6th position for V3 voltage*

ETO-110SX-25

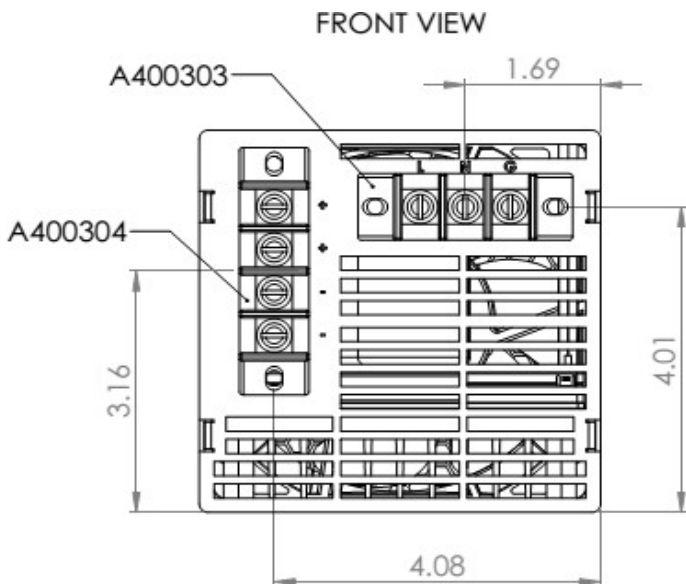

INPUT INTERFACE TERMINAL BUCHANAN A400303	
Designation	Function
L	Line
N	Neutral
G	Ground

OUTPUT INTERFACE TERMINAL BUCHANAN A400304 (Top to bottom)	
Designation	Function
+	+Vout
+	+Vout
-	Vout Return
-	Vout Return



DIMENSIONAL DRAWING

